

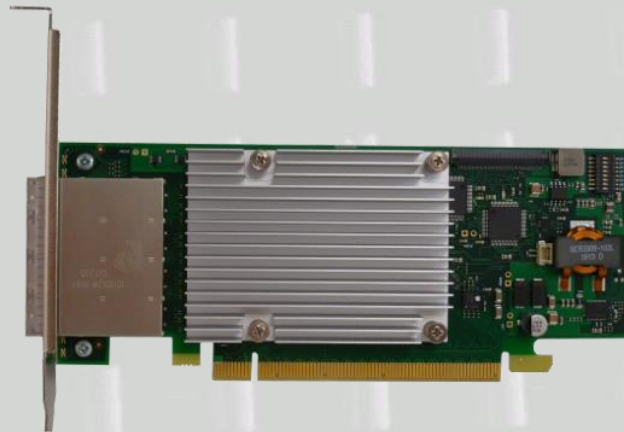

# Dolphin PCI Express MXH830 Adapter



MXH830 NTB Adapter Users Guide  
Version 1.0

Date: 17<sup>th</sup> April 2018



## Table of Contents

<b>DISCLAIMER</b> .....	<b>4</b>
<b>TERMS AND ACRONYMS</b> .....	<b>4</b>
<b>MXH830 HIGH LEVEL SPECIFICATION</b> .....	<b>5</b>
<b>PACKAGING</b> .....	<b>6</b>
<b>PRE-INSTALLATION QUESTIONS</b> .....	<b>6</b>
PCIE SLOT DETERMINATION.....	6
MXH830 NTB CONFIGURATION.....	6
OPERATING ENVIRONMENT.....	6
CABLE CONNECTIONS.....	6
<i>Active Optical Cables (AOC)</i> .....	7
<b>INSTALLATION</b> .....	<b>8</b>
STEP 1 - UNPACK BOARD .....	8
STEP 2 - CHANGE PCIE BRACKET IF NECESSARY .....	8
STEP 3 - CONFIGURE THE BOARD FOR PROPER OPERATION .....	8
STEP 4 - INSTALL THE ADAPTER CARD.....	8
STEP 5 - INSTALLING AND REMOVING THE CABLE.....	8
<i>Connecting the Cable</i> .....	8
<i>Disconnecting the Cable</i> .....	9
STEP 6 - INSTALLING THE DOLPHIN EXPRESSWARE SOFTWARE .....	9
STEP 7 – VERIFY INSTALLATION & LEDs .....	9
<b>OPERATION</b> .....	<b>10</b>
CONFIGURATION AND DIP SWITCHES.....	10
<i>DIP Switch Bank – Configuration</i> .....	10
USE CASE A - 2 NODE CONFIGURATION – NTB MODE.....	11
<i>Connecting the cables for 2 Node Configurations, x16 link</i> .....	11
<i>Connecting the cables for 2 Node Configurations, x8 link</i> .....	11
<i>Connecting the cables for 2 Node Configurations, x4 link</i> .....	11
USE CASE B - 3 NODE CONFIGURATION – NTB MODE.....	12
<i>Connecting the cables for 3 Node Configurations, x8 link</i> .....	12
USE CASE C - 5 NODE CONFIGURATION – NTB MODE.....	12
<i>Connecting the cables for 5 Node Configurations, x4 link</i> .....	12
USE CASE D – SWITCH CONFIGURATIONS – NTB MODE .....	13
EEPROM AND FIRMWARE UPGRADE .....	14
IDENTIFYING THE CARD.....	14
SUPPORT .....	16
<b>TECHNICAL INFORMATION</b> .....	<b>17</b>
BOARD REVISION HISTORY .....	17
SIMPLIFIED SCHEMATICS .....	17
PCIE CABLE PORT SIGNALS .....	18
EXTERNAL PCIE X4 CABLE CONNECTOR PIN-OUT .....	18
PCIE CABLE PORT MAPPING .....	18
<b>COMPLIANCE AND REGULATORY TESTING</b> .....	<b>19</b>
<b>LIMITED WARRANTY</b> .....	<b>20</b>
WARRANTY PERIOD.....	20

COVERAGE.....	20
SERVICE PROCEDURE .....	20

## DISCLAIMER

DOLPHIN INTERCONNECT SOLUTIONS RESERVES THE RIGHT TO MAKE CHANGES WITHOUT FURTHER NOTICE TO ANY OF ITS PRODUCTS TO IMPROVE RELIABILITY, FUNCTION, OR DESIGN.

TO THE FULLEST EXTENT PERMITTED BY LAW, DOLPHIN WILL NOT BE LIABLE FOR ANY INDIRECT, INCIDENTAL, SPECIAL OR CONSEQUENTIAL DAMAGES (INCLUDING LOST PROFITS, LOST DATA, OR LOSS OF USE) ARISING OUT OF ANY USE OF DOLPHIN'S PRODUCTS, SOFTWARE OR SERVICE PROVIDED. DOLPHIN'S MAXIMUM LIABILITY WILL NOT EXCEED THE TOTAL AMOUNT PAID FOR THE PRODUCT BY THE PURCHASER.

### LIFE SUPPORT POLICY

DOLPHIN INTERCONNECT SOLUTIONS' PRODUCTS ARE NOT AUTHORIZED FOR USE AS CRITICAL COMPONENTS IN LIFE SUPPORT DEVICES.

### ENVIRONMENTAL POLICY

Dolphin is minimizing the amount of printed documentation and software CDs in its shipments; please download additional documentation and software from [www.dolphinics.com](http://www.dolphinics.com).

## Terms and acronyms

Important terms and acronyms used in this manual

AOC	<b>Active Optical Cable.</b> PCIe fiber cable assembly.
CMI	<b>Cable Management Interface.</b> The 2-wire management interface for communication between subsystems connected by a PCIe 3.0 cable. Details can be found in the PCI-SIG External Cabling Specification 3.0.
CMI Controller	Microcontroller on the MXH830 used to manage and implement the CMI communications.
eXpressWare	Dolphin's software stack for PCIe clustering and IO. Please visit <a href="http://www.dolphinics.com">www.dolphinics.com</a> for more information.
Host mode	The card is installed in a root complex / Host PC.
Lane	One PCI Express Lane contains a differential pair for transmission and a differential pair for reception.
Link	A collection of one or more PCI Express Lanes providing the communication path between an Upstream and Downstream Port.
MiniSAS-HD	Standard cable without CMI support.
PCIe 3.0 cable	Cable compliant to the preliminary PCI-SIG External Cabling Specification 3.0. Support for CMI.
Port	PCIe Cable port. The MXH830 has four x4 ports, named P1, P2, P3, P4. These ports can be merged to two x8 ports, or one x16 port. The physical ports are identified by text on the PCIe brackets.

## MXH830 High Level Specification

The MXH830 is a low profile, half-length PCIe adapter that can be used for NTB and Transparent configurations. Once installed in any server's or PC's PCI Express compliant slot, a MXH830 can connect to another MXH830 or the MXS824 switch. The MXH830 supports PCIe Gen1, Gen2 and Gen3 speeds and x1, x2, x4, x8 and x16 link-widths. The card will operate at the highest common speed shared between the slot and the card (Gen3) and the widest common link-width (x16).

- PCI Express Base Specification, Rev. 3.1.
- PCI Express CEM Specification, Rev. 3.0.
- PCI Express External Cabling specification 3.0 (Work in progress, rev 0.7)
- PCI Express Gen3 8.0 GT/s per lane signaling – 128 GT/s total signaling.
- PCI Express Gen3 x16 edge connector. The card installs in any PCI Express slot that has a physical x16 connector.
- Compliant with PCI Express Gen1 through Gen3 computers and IO systems, auto detection.
- Quad SFF-8644 cable connector
- Cable port configurations
  - One x16 NTB port
  - Two x8 NTB ports
  - Four x4 NTB ports
- Microsemi Switchtec PM8532 PFX PCI Express Gen3 chipset.
- Pre-loaded NTB and Transparent configurations, DIP switch selectable.
- 170 nanosecond cut-through latency port to port.
- Support for MiniSAS-HD copper cables, MiniSAS-HD fiber optic cables and PCI Express 3.0 copper cables with CMI.
- Support for active optical fibers up to 100 meters.
- Low profile, Half-length - PCI Express Electromechanical Specification, Rev 3.0.
- Dimensions 167.65mm (6.600 inches) x 68.90 mm (2.731 inches)
- Comes with both low profile and standard profile PCI Express bracket.
- Host clock isolation. Automatic support for host running CFC or SSC mode.
- VAUX powered board management controllers for flexible configuration and cable management.
- Flash recovery option. PFX Multi configuration support.
- Power consumption:
  - 12 Volt: Max 19.6 Watts without AOC attached.
  - 12 Volt: Max 26 Watts with 4 AOCs attached
  - +3.3 Volt: Not connected
  - +3.3 Volt AUX: 1 W
- Port power supply (per cable port): 3.3 Volt +/- 5%, 0.6 A
- Operating Temperature: 0°C - 55°C (32°F - 131°F), Air Flow: 150 LFM
- Operating Temperature with AOC: 0°C - 45°C (32°F - 113°F), Air Flow: 150 LFM
- Operating Temperature: 0°C - 50°C (32°F - 122°F), Air Flow: ~0 LFM
- Relative Humidity: 5% - 95% (non- condensing)
- Regulatory:
  - CE
  - EN-55032, EN 55024, Class A.
  - RoHS
  - FCC 15 Subpart B Class A.
  - WEEE
  - Pending Korean KC mark

## Packaging

The MXH830 includes the following components.

- MXH830 Adapter Board
- Low profile bracket
- Anti-static bag
- Getting started guide with serial number for quick download of Dolphins eXpressWare PCIe software.

## Pre-Installation Questions

Certain steps should be taken prior to installing the MXH830. You should determine the following configuration requirements.

- Which PCIe slot and system will the card be installed in?
- Will the board act as a host adapter or target adapter?
- What is the speed and link width of the slot that the card will be installed in?
- What is the operating environment in which the card will be installed?
- What type and length of cables will be used?
- How to establish proper operational conditions, temperature and air-flow.

## PCIe Slot Determination

The MXH830 supports PCIe Gen1, Gen2 and Gen3 speeds and x1, x2, x4, x8 and x16 link-widths. The slot width and speed will affect the performance of the card. The card can be physically installed in a x4, x8 or x16 connector. The card will auto configure to the slot speed and width.

- Install the board in a slot connecting directly to the CPU for optimal shared memory performance.
- Install the board behind a PCIe switch in the IO system for optimal PCIe peer to peer performance (e.g. between GPUs, FPGAs)

**TIP:** After installing the eXpressWare software, run the “sisci\_benchmarks” benchmark suite to verify the expected performance. Please contact Dolphin support if you need assistance to reach the expected performance.

## MXH830 NTB Configuration

The MXH830 has a DIP switch bank to control the main configuration of the card. The DIP switch labeled SW1 can be found close to the upper edge of the board. The default DIP switch setting is single link x16 operations. Alternative configuration settings are two x8 links or four x4 links.

## Operating Environment

To maximize life time for the product and maintain the warranty, please honor the specified operating temperature and make sure the specified air flow is present. Special care should be considered when MXH830 is used in office type cabinets in combination with other high energy consuming PCIe devices, e.g. not active cooled GPUs:

Operating Temperature: 0°C - 55°C (32°F - 131°F), Air Flow: 150 LFM  
Operating Temperature with AOC: 0°C - 45°C (32°F - 113°F), Air Flow: 150 LFM  
Operating Temperature: 0°C - 50°C (32°F - 122°F), Air Flow: ~0 LFM  
Relative Humidity: 5% - 95% (non- condensing)

**TIP:** After installing the Dolphin eXpressWare software, you can use the tool dis\_diag to determine the actual board temperatures

## Cable Connections

The MXH830 is designed to support both long and short copper cables as well as active optical cables (AOC).

The MXH830 cable connector is compliant to the SFF-8644 industry specification and supports standard x4/x8 Mini-SAS HD cables or x4/x8 PCI Express 3.0 cables compliant to the PCIe External Cabling Specification 3.0. Four x4 or two x8 cables are needed for full PCIe x16 connectivity. Currently, the MXH830 card does not benefit from the new PCIe 3.0 cable, a future firmware release may add support for optional, advanced PCIe networking management if PCIe 3.0 cables are installed.

### **Active Optical Cables (AOC)**

The MXH830 card is compliant with active fiber optic cables up to 100 meters. Special configuration of the card needs to be performed for working with long fibers (Contact Dolphin).

# Installation

## Step 1 - Unpack board

The MXH830 card is shipped in an anti-static bag to prevent static electricity damage. The card should only be removed from the bag after ensuring that anti-static precautions are taken. Static electricity from your clothes or work environment can damage your PCI Express adapter card or your PC. Always wear a grounded anti-static wrist strap while opening the PC and when the MXH830 is removed from the anti-static bag.



Unpack the MXH830 from the anti-static bag using proper anti-static procedures.

## Step 2 - Change PCIe Bracket if necessary

The MXH830 package includes a standard and low-profile PCI Express bracket. By default, the standard height bracket is installed on the board. If you need to replace the mounted bracket with a low-profile bracket, carefully unscrew the two mounting screws to remove the full height bracket. Save the two mounting screws and replace the bracket with the low-profile bracket. Use the two mounting screws to install the low-profile bracket. The screws should be carefully tightened but be careful not to over-tighten. Make sure you are properly grounded to avoid static discharges that may destroy the adapter card before performing this procedure.

## Step 3 - Configure the Board for Proper Operation

Set the DIP switch settings for proper operation depends on the firmware. Please refer to the section Configuration and DIP Switches on page 10 for details.

## Step 4 - Install the Adapter Card

Before installing the adapter card, make sure you are properly grounded to avoid static discharges that may destroy your computer or the adapter card. Ensure you are properly grounded before opening your computer or the anti-static bag containing the MXH830. Please follow your computer's or expansion chassis manual on how to install a PCI Express card.



The MXH830 Adapter card can be installed into any PCI Express x16 slot. The MXH830 supports PCI Express Gen1, Gen2 and Gen3 signaling. NOTE: A Gen3 slot is recommended as it typically doubles the performance compared to a Gen2 slot. The MXH830 is an x16 card, so maximum performance will only be attained if the slot provides full electrical x16 signaling. The MXH830 supports hosts using either spread spectrum or constant frequency clocking. The card implements clock isolation.

## Step 5 - Installing and Removing the Cable

Installing and removing cables should be done with both host and expansion system powered off. Please contact your Dolphin representative if you intend to continuously connect and disconnect the PCI Express cables.

### Connecting the Cable

Please carefully install the cable connector into the connector housing on the MXH830 adapter card. To install the cable, match the cable house with the connector on the MXH830 adapter card. Use even pressure to insert the connector until it is secure. Adhere to ESD guidelines when installing the cables to ensure you don't damage the board. Computer cables should always use strain relief to protect the connected equipment from excessive force on the cable. This is especially important for cables between racks. Note that for wider than x4 connections, the same cable-ports (ie port 1 through 4) should be used on both host and target for each individual cable, to ensure that the cards properly link up as x8 or x16.

The MXH830 supports both copper and active optical cables (AOC). Project targets can be found in Table 1 below. Long cable qualification in progress, please contact Dolphin for details.

Cable	Speed	Distance
Copper MiniSAS-HD	Gen3	9 meters
Copper MiniSAS-HD	Gen1	12 meters
Copper PCIe 3.0 cable	Gen3	TBD
Fiber optic (AOC)	Gen3	TBD

Table 1: Cable Specifications



### Disconnecting the Cable

Please carefully pull the release tab to release the cable from the locking latches and gently pull the cable out of the connector guides.

## Step 6 - Installing the Dolphin eXpressWare Software

The MXH830 adapter card is compliant with Dolphin's eXpressWare software package for the MX product line. Please visit

<http://www.dolphinics.com/mx.html>

to register and download the latest documentation and software. It is recommended to follow the quick installation guide found on the web page above to install the software for your operating system.

**TIP:** Dolphin provides software and documentation for several product families; **please remember to select the MX product family before downloading.** The MXH830 requires Dolphin software version DIS 5.6.0 or higher to operate.

The software download requires a password to log in. **The password will automatically be emailed to you if you follow the instructions found on the getting started document bundled with the adapter card.** If you fail to provide the correct serial number found on the getting started document, your request will be managed manually.

## Step 7 – Verify Installation & LEDs

The MXH830 comes with 4 bi-color LEDs which show the corresponding cable port status according to Table 2: LED below.

The LEDs are visible through cut-outs in the PCIe bracket on each side of the cable connector block.

LED color	Function
Off	No cable installed
Yellow	Cable installed, no link
Green	Cable installed, link gen 3
Green blinking	Cable installed, link gen 1/2

Table 2: LED behavior

# Operation

## Configuration and DIP Switches

The MXH830 has one bank of 8 DIP switches. The default factory setting for the MXH830 is x16 NTB link connection suitable for a two-node configuration or connection to the MXS824 switch.

The MXH830 has DIP switches for setting special modes or operations, the meaning of each DIP switch depends on the loaded firmware. Please carefully read the documentation shipping with the card before modifying any DIP switch settings. Please pay close attention to ON and OFF positions written on the DIP switch.

### DIP Switch Bank – Configuration

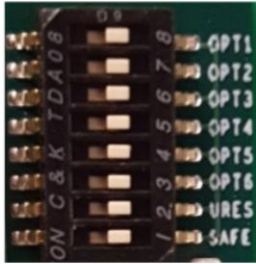

Figure 1: DIP Switch shows the DIP switch for the MXH830. It is used to configure the adapter card. Please leave all undocumented DIP switches in the default position. Table 3: DIP Switch settings shows all the various DIP switch NTB settings for the MXH830.

Figure 1: DIP Switch

DIP no.	Name	Description	ON	OFF	Default
1-4	OPT1-4	Configuration selector, details below			Opt4: on
5	OPT5	CMI Disable	Will disable the CMI interface.	CMI will be used if a PCIe 3.0 cable is detected	OFF
6	OPT6	Reserved for future use			OFF
7	URES	Holds the management processors in reset	Board management is held in reset	Normal operation	OFF
8	SAFE	Enables the card to boot if the EEPROM has been corrupted	Safe EEPROM	Normal operation	OFF

Table 3: DIP Switch settings

Note: DIP switch configuration options may be changed in the future versions. Please always consult the latest user guide for details.

## NTB Use Cases Summary and DIP Settings

The MXH830 card may be used in the following NTB use cases. Please contact Dolphin if you have other requirements for BAR size.

Use case	Description	BAR SIZE	DIP switch setting
A	Two node NTB configuration. Both systems have MXH830 installed.	256 Megabytes	Opt4: on
		32 Gigabytes	Opt4: on Opt1: on
B	Three node NTB configuration. All systems have a MXH830 installed	256 Megabytes	Opt4: on Opt2: on
		32 Gigabytes	Opt4: on Opt2: on Opt1: on

<b>C</b>	Five node NTB configuration. All systems have a MXH830 installed	256 Megabytes	Opt4: on Opt3: on
		32 Gigabytes	Opt4: on Opt3: on Opt1: on
<b>D</b>	Multi node with MXS824 switch (same DIP switch setting as use casa A)	256 Megabytes	Opt4: on
		32 Gigabytes	Opt4: on Opt1: on

**Table 4: Use Case DIP switch settings**

## Transparent Operation

The MXH830 card can also operate as a transparent host and target adapter. Please refer to the MXH832 users guide for DIP switch settings.

## Use Case A - 2 Node Configuration – NTB Mode

Each node has a MXH830 adapter and a direct x4, x8 or x16 cable connection to the other system. This configuration is fully supported by all Dolphin software, from version DIS 5.6.0 and newer. Both MXH830 adapter cards operate in NTB mode. The DIP-Switch is set to all off, except if a long cable is used.

### Connecting the cables for 2 Node Configurations, x16 link

To establish an x16 link, a given port number should be connected to the same port number on the other card.

Table 5: Required x16 cabling. Always connect a cable from Port #x to Port #x

Port, Host A	Port, Host B
P1	P1
P2	P2
P3	P3
P4	P4

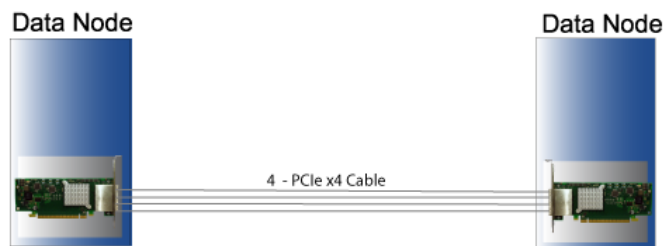

A failure connecting any of the cables will cause the link to re-train to x8 or x4.

### Connecting the cables for 2 Node Configurations, x8 link

To establish an x8 link, please select one of the alternatives below.

Table 6: Alternative x8 cabling, select alternative 1, 2, 3 or 4.

Alternatives	Host A	Host B
1	P1	P1
	P2	P2
2	P1	P3
	P2	P4
3	P3	P1
	P4	P2
4	P3	P3
	P4	P4

### Connecting the cables for 2 Node Configurations, x4 link

To establish an x4 link when in dual port mode, please connect any port to any port on the other card.

## Use Case B - 3 Node Configuration – NTB Mode

Each node has a MXH830 adapter and a direct x4 or x8 cable connection is used between all systems. This configuration is fully supported by all Dolphin software, from version DIS 5.6.0 and newer. All MXH830 adapter cards operate in NTB mode.

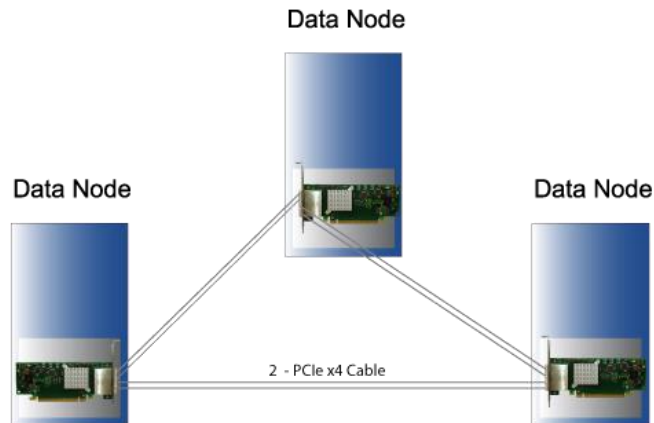

### Connecting the cables for 3 Node Configurations, x8 link

Connect the cables between two nodes as described above, connecting two nodes x8. Connect the third node to the two other cards using similar rules. Always connect P1 + P2 to P1 + P2 or P3 + P4

## Use Case C - 5 Node Configuration – NTB Mode

Each node has a MXH830 adapter and a direct x4 cable connection is used between all systems. This configuration is fully supported by all Dolphin software, from version DIS 5.7.0 and newer. All MXH830 adapter cards operate in NTB mode.

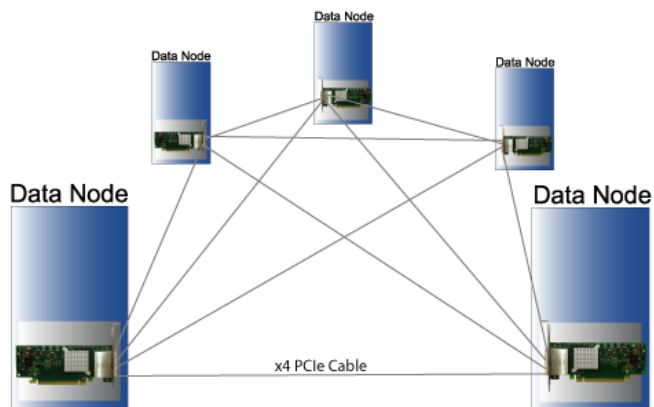

### Connecting the cables for 5 Node Configurations, x4 link

Connect any cable/port to any port on the remote system ensuring there is a single x4 cable directly between all nodes.

## Use Case D – Switch Configurations – NTB Mode

The HXH830 card can be combined with the MXS824 24 port PCIe switch to create larger PCIe networks. Each node typically has a MXH830 adapter and a x4, x8 or x16 cable connection to the MXS824 switch. This configuration is fully supported by all Dolphin software, from version DIS 5.7.0 and newer. All MXH830 adapter cards operate in NTB mode. Please consult the MXS824 Users Guide for more details.

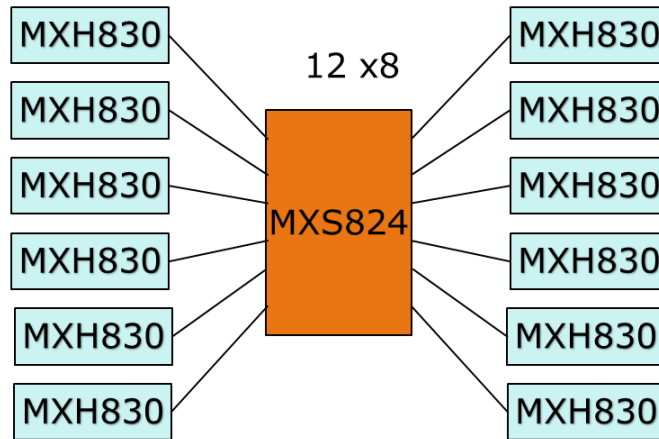

Figure 2: A 12 node PCIe x8 network

## EEPROM and Firmware Upgrade

The MXH830 design uses a microcontroller to implement the PCIe CMI protocol and other maintenance functions. Dolphin may from time to time publish updated firmware for the microcontroller or EEPROM data for the card. Please contact Dolphin for instructions on how to upgrade the MXH830. Please note that standard Microsemi firmware tools cannot be used to upgrade the firmware.

## Identifying the Card

The card has a label-sticker with the serial number in the format 'MXH830-YY-ZZZZZ', where YY denotes the card revision (e.g. BB) and ZZZZZ denotes the serialized production number (e.g. 012345) – this whole string makes up the serial number of the card (i.e. MXH830-CF-012345).

You can also get this information using `lspci` in Linux:

First, identify the devices for the Dolphin Host card:

```
# lspci | grep "Device 8532"

01:00.0 PCI bridge: PMC-Sierra Inc. Device 8532
01:00.1 Memory controller: PMC-Sierra Inc. Device 8532
02:00.0 PCI bridge: PMC-Sierra Inc. Device 8532
```

Then run `lspci` and identify the card. It will show up as something like

```

# lspci -s 1:0.0 -v
01:00.0 PCI bridge: PMC-Sierra Inc. Device 8532 (prog-if 00 [Normal decode])
    Flags: bus master, fast devsel, latency 0, IRQ 25
    Bus: primary=01, secondary=02, subordinate=03, sec-latency=0
    I/O behind bridge: 00002000-00002fff
    Prefetchable memory behind bridge: 00000000df200000-00000000df3fffff
    Capabilities: [40] Express Upstream Port, MSI 00
    Capabilities: [7c] MSI: Enable+ Count=1/8 Maskable- 64bit+
    Capabilities: [8c] Power Management version 3
    Capabilities: [94] Subsystem: Dolphin Interconnect Solutions AS Device 0830
    Capabilities: [100] Advanced Error Reporting
    Capabilities: [138] Power Budgeting <?>
    Capabilities: [148] #12
    Capabilities: [178] #19
    Capabilities: [1a4] Device Serial Number 00-00-42-42-00-00-00-ff
    Capabilities: [1b0] Latency Tolerance Reporting
    Capabilities: [1b8] Access Control Services
    Capabilities: [7f8] Vendor Specific Information: ID=ffff Rev=1 Len=808 <?>
    Kernel driver in use: pcieport
    Kernel modules: shpchp

# lspci -s 1:0.1 -v
01:00.1 Memory controller: PMC-Sierra Inc. Device 8532
    Subsystem: Dolphin Interconnect Solutions AS Device 0830
    Flags: bus master, fast devsel, latency 0
    Memory at f7800000 (64-bit, non-prefetchable) [size=4M]
    Capabilities: [40] MSI: Enable- Count=1/4 Maskable- 64bit+
    Capabilities: [50] MSI-X: Enable- Count=4 Masked-
    Capabilities: [5c] Power Management version 3
    Capabilities: [64] Express Endpoint, MSI 00
    Capabilities: [100] Advanced Error Reporting
    Capabilities: [138] Device Serial Number 00-00-42-42-00-00-00-ff
    Capabilities: [144] Access Control Services

# lspci -s 2:0.0 -v
02:00.0 PCI bridge: PMC-Sierra Inc. Device 8532 (prog-if 00 [Normal decode])
    Flags: bus master, fast devsel, latency 0, IRQ 26
    Bus: primary=02, secondary=03, subordinate=03, sec-latency=0
    I/O behind bridge: 00002000-00002fff
    Prefetchable memory behind bridge: 00000000df200000-00000000df3fffff
    Capabilities: [40] Express Downstream Port (Slot+), MSI 00
    Capabilities: [7c] MSI: Enable+ Count=1/8 Maskable- 64bit+
    Capabilities: [8c] Power Management version 3
    Capabilities: [94] Subsystem: Dolphin Interconnect Solutions AS Device 0830
    Capabilities: [100] Advanced Error Reporting
    Capabilities: [138] Power Budgeting <?>
    Capabilities: [148] #12
    Capabilities: [178] #19
    Capabilities: [1a4] Device Serial Number 00-00-42-42-00-00-00-ff
    Capabilities: [1b0] Downstream Port Containment
    Capabilities: [1bc] Access Control Services
    Capabilities: [7f8] Vendor Specific Information: ID=ffff Rev=1 Len=808 <?>
    Kernel driver in use: pcieport
    Kernel modules: shpchp

```

Second, do

```
# lspci -s 1:0.0 -v | grep -E "Subsystem|Serial"  
Capabilities: [a4] Subsystem: Dolphin Interconnect Solutions AS Device 0830  
Capabilities: [100] Device Serial Number 00-00-42-42-00-00-00-ff
```

This shows the card as revision 0x4242 (hexadecimal values of the 'BB' letters in the ASCII table), with the production number 0x000000ff (00000255 in decimal).

## Support

More information about the product, support and software download at <http://www.dolphinics.com/mx.html>. Please email [pci-support@dolphinics.com](mailto:pci-support@dolphinics.com) if you have any questions.



# Technical Information

## Board revision history

The following table gives a general overview of the hardware revision history.

Adapter card revision	Capabilities
MXH830-CE	<ul style="list-style-type: none"> <li>Initial product version</li> </ul>
MXH830-CF	<ul style="list-style-type: none"> <li>New improved heat sink with better mounting.</li> <li>Current shipping version.</li> </ul>

## Simplified schematics

The figure below shows the MXH820 simplified schematics. Only the main functions are shown.

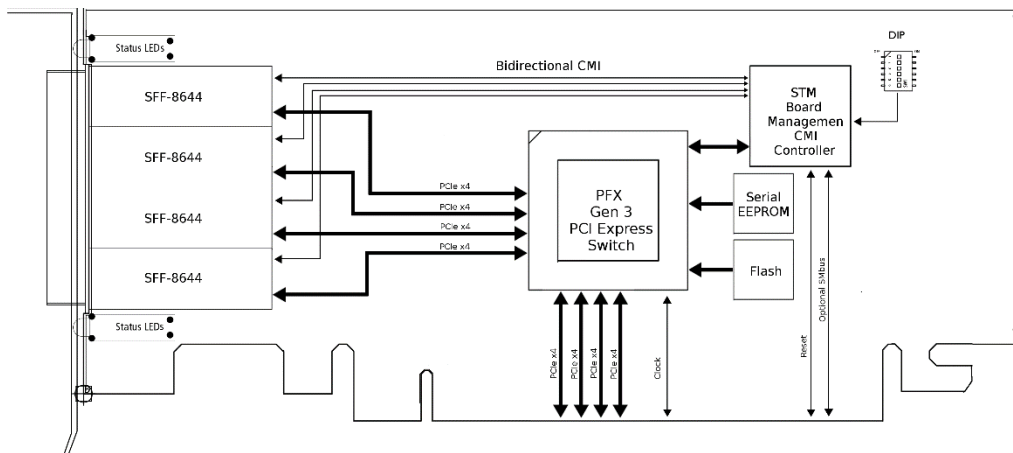

Figure 3: MXH830 Simplified Schematics

## PCIe Cable Port Signals

The external PCI Express SFF-8644 cable connector supports the following signals:

- PETpN/PETnN: PCI Express Transmitter pairs, labeled where N is the Lane number (starting with 0); “p” is the true signal while “n” is the complement signal.
- PERpN/PERnN: PCI Express Receiver pairs, labeled where N is the Lane number (starting with 0); “p” is the true signal while “n” is the complement signal.
- PWR: Power to support AOC and signal conditioning components within the cable assembly.
- MGTPWR: Power supplied to the connector for cable management components that are needed while the link is not active. This needs to be active if the subsystem has power.
- CBLPRSNT#: Cable present detect, an active-low signal pulled-down by the cable when it is inserted into the MXH830 connector.
- CADDR: Signal used to configure the upstream cable management device address.
- CINT#: Signal asserted by the cable assembly to indicate a need for service via the CMI controller.
- CMISDA: Management interface data line. Used for both initial link setup and sideband messages when used with CMI compliant cables.
- CMISCL: Management interface clock line. Used for both initial link setup and sideband messages when used with CMI compliant cables.

## External PCIe x4 Cable Connector Pin-Out

	Column								
Row	9	8	7	6	5	4	3	2	1
D	GND	PETn2	PETp2	GND	PETn1	PETp1	GND	MGTPWR	PWR
C	GND	PETn3	PETp3	GND	PETn0	PETp0	GND	CMISDA	CMISCL
B	GND	PERn2	PERp2	GND	PERn1	PERp1	GND	CBLPRSNT#	PWR
A	GND	PERn3	PERp3	GND	PERn0	PERp0	GND	CINT#	CADDR

Table 7; External PCIe x4 cable Pin-Out

## PCIe Cable Port Mapping

The MXH830 card have a quad SFF-8644 connector. The table below show the signal / port map.

Cable Port	x16	Dual x8	Quad x4	PCIe 3.0 Cable Pin
1	L15	L7	L3	TX3/RX3
	L14	L6	L2	TX2/RX2
	L13	L5	L1	TX1/RX1
	L12	L4	L0	TX0/RX0
2	L11	L3	L3	TX3/RX3
	L10	L2	L2	TX2/RX2
	L9	L1	L1	TX1/RX1
	L8	L0	L0	TX0/RX0
3	L7	L7	L3	TX3/RX3
	L6	L6	L2	TX2/RX2
	L5	L5	L1	TX1/RX1
	L4	L4	L0	TX0/RX0
4	L3	L3	L3	TX3/RX3
	L2	L2	L2	TX2/RX2
	L1	L1	L1	TX1/RX1
	L0	L0	L0	TX0/RX0

Lx – PCIe lane X, Cable port is ref PCIe bracket marking

Table 8 : PCIe Cable Port Mapping

## Compliance and Regulatory Testing

### *EMC Compliance*

The Dolphin PCI Express MXH830 adapter is tested to the following relevant test standards for PCI Express cards, telecommunication and industry equipment installed in a standard PC:

EN 55032  
EN 55024, Class A



This does not ensure that it will comply with these standards in any random PC. It is the responsibility of the integrator to ensure that their products are compliant with all regulations where their product will be used.

### *RoHS Compliance*

The Dolphin MXH830 is RoHS compliant. A Compliance certificate issued by the manufacturer is available upon request.



### *FCC Class A*

This equipment is tested and found to comply with the limits for a Class A digital device, pursuant to part 15 of the FCC Rules.



## Limited Warranty

Dolphin Interconnect Solutions warrants this product to be free from manufacturing defects under the following terms:

### Warranty Period

Dolphin warrants the product for one (1) year from the date of purchase. Extended warranties are available.

### Coverage

To the extent permitted by applicable law, this warranty does not apply to:

- Damages caused by operator error or non-compliance with instructions available for the product.
- Use or attempt to use or program firmware not approved by Dolphin.
- Damage which results from accident, abuse, misuse, neglected improper handling or improper installation; moisture, corrosive environments, high voltage surges, shipping or abnormal working conditions.
- Damages which results from violating the specified operating or storage temperatures and airflow.
- Damages caused by acts of nature, e.g. floods, storms, fire, or earthquakes.
- Damage caused by any power source out of range or not provided with the product.
- Normal wear and tear.
- Attempts to repair, modify, open or upgrade the product by personnel or agents not authorized by Dolphin.
- Products that have had the product serial number tampered with or removed.
- Damage to the product caused by products not supplied by Dolphin.

### Service Procedure

If the product proves defective during the Warranty Period, you should contact the seller that supplied you with the product, or if you purchased it directly from Dolphin, email [returnrequests@dolphinics.com](mailto:returnrequests@dolphinics.com) to obtain a valid RMA number and instructions.

Products returned to Dolphin without a proper RMA number will not be serviced under this warranty.